

CITY OF JOHNSTOWN, PENNSYLVANIA

RESOLUTION NO. 10556

A RESOLUTION OF THE CITY COUNCIL OF THE CITY OF JOHNSTOWN, CAMBRIA COUNTY, PENNSYLVANIA AUTHORIZING THE CITY MANAGER TO SIGN ALL DOCUMENTS NECESSARY TO PURCHASE A 2024 10-TON MACK CHASSIS FROM M & K TRUCK CENTER AND AN 11' ALUMINUM DUMP BED WITH SNOW EQUIPMENT FROM A & H EQUIPMENT

WHEREAS, the City of Johnstown Public Works Department would like to purchase a 2024 10-ton Mack truck chassis from M & K Truck Center and a 11' Aluminum Dump body with Snow Equipment from A & H Equipment; and

WHEREAS, the purchase of the truck chassis and dump body will be made from First Capital Equipment Leasing Corp. for (7) seven year paid quarterly with an annual payment of \$32,553.29 not including interest; and

WHEREAS, the purchase is budgeted within the City's 2023 Capital Budget, line item number 18.434.74.072.00; and

WHEREAS, during a search for a 2024 10-ton Mack truck chassis and Aluminum Dump Body M & K Truck Center and A & H Equipment offered the lowest COSTAR quote for a 2024 10-ton truck at \$152,303.00 and the Aluminum Dump Body with Snow Equipment \$75,570.00 for a total quote of \$227873.00 leased for (7) seven years paid quarterly with an annual payment of \$32,553.29 not including interest.

NOW, THEREFORE, BE IT RESOLVED, the City Council of the City of Johnstown, hereby authorizes the City Manager and/or his designee to sign all documents and take all actions necessary to lease from First Capital Equipment Leasing Corp. the 2024 10-ton Mack Truck chassis from M & K Truck Center and 11' Aluminum Dump Body with Snow Equipment from A & H Equipment.

ADOPTED: March 8, 2023

By the following vote:

Yeas: Mayor Janakovic, Mr. Arnone, Rev. King, Mr. Britt, Mrs. Mock, Mr. Capriotti, Ms. Huchel

Nays:

Absent:



Frank Janakovic, Mayor
Michael Capriotti, Deputy Mayor

ATTEST:

I do hereby certify that the foregoing is a true and correct copy of Resolution No. **10556** as the same adopted by the City Council of the City of Johnstown, Pennsylvania.



Ethan Imhoff, City Manager

CUSTOMER PROPOSAL

MAEK®

2024 Granite Version 4 2/6/2023
Corrected Paint and H rated rear tires



JOHNSTOWN
419 6TH AVE
JOHNSTOWN
PA 159062547

2/6/2023

M & K TRUCK CENTER OF ALTOONA, LLC
649 BRUSH MOUNTAIN ROAD
ALTOONA
PA 16601-8971

MEYE2023000010A501
GRANITE 42FR
Qty: 1

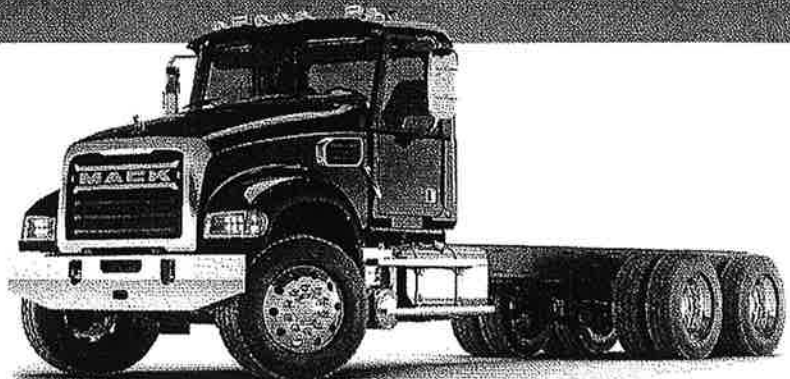

PRICING SUMMARY GRANITE 42FR

VEHICLE PRICE

\$150,203.00

SOFT OFFERS AND WARRANTY

CARB + EPA for Mack MP7 / MP8 Diesel

\$2,100.00

TAX SUMMARY

AMT. SUBJECT TO TAX

FET (12%)

N/A

\$0.00

TOTAL QUOTE PRICE (PER VEHICLE)

\$152,303.00

JOHNSTOWN

DATE

M & K TRUCK CENTER OF ALTOONA, LLC

DATE



VEHICLE SPECIFICATION/CALCULATED PERFORMANCE SUMMARY

Descriptor	Sales Code	Dim. Ref.	Length	UCM
Front Frame Extension	N/A	FE	6.1	INCHES
Bumper to Front Axle	N/A	BA	29.0	INCHES
Wheelbase	N/A	WB	197.2	INCHES
Rear Overhang	N/A	OH	66.7	INCHES
Overall Length	N/A	OL	299.1	INCHES
Bumper to Back of Cab	N/A	BBC	116.5	INCHES
Eff. Bumper to Back of Cab	N/A	EBBC	122.6	INCHES
Eff. Cab to Rear Axle	N/A	ECA	109.7	INCHES
Eff. Front Axle to Back of Cab	N/A	EAC	87.5	INCHES
Eff. Cab to End of Frame	N/A	ECEF	176.5	INCHES
Unladen 5th Wheel Height	E5BZ1X	5W	0.0	INCHES
Unladen Frame Height	N/A	FH	42.8	INCHES
Cab Height	N/A	CH	70.9	INCHES
Overall Height	N/A	OVH	116.8	INCHES
Driver CG	N/A	DCG	70.9	INCHES
Second Front Axle Spacing	RHXZ1X	SFAS	0.0	INCHES

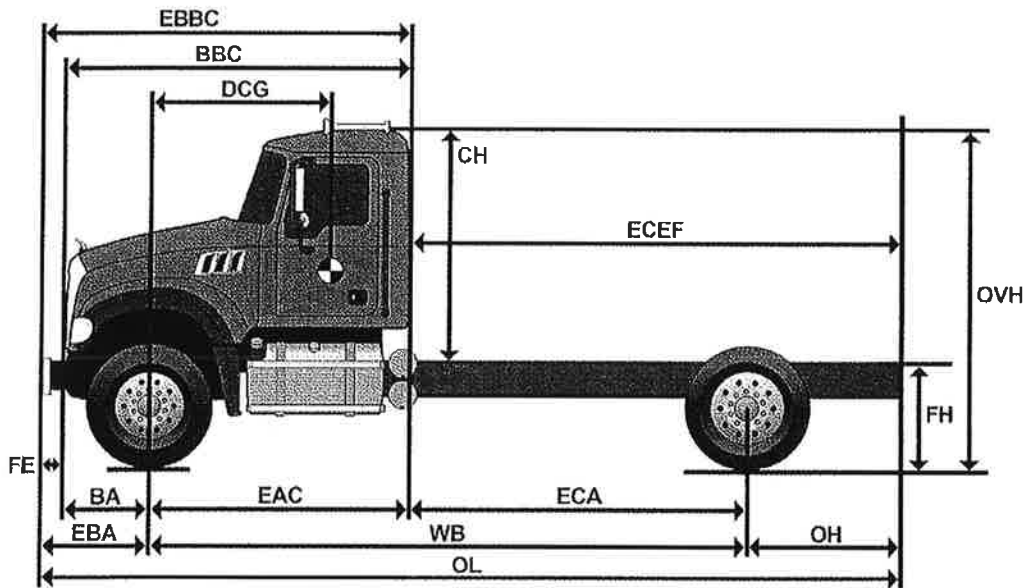



PITTSBURGH - 620 W Beaver Street, Zelienople, PA 16063 412-257-1160

HARRISBURG - 1405 B Hagy Way, Harrisburg, PA 17110 717-724-0310

SOMERSET - 241 E Garrett Street, Somerset, Pa 15501 814-444-6403

800-753-7566 Fax PGH: 412-257-4471 Fax HAR - 717-724-0309

Customer	City of Johnstown		
Name	Jared Campagna		
Address	419 Sixth Street		
City	Johnstown	State PA	ZIP 15901
Phone			

Misc	QUOTE
Date	2/17/2023
Quote No.	02152023AL
Rep	PMO

Qty	Description	Unit Price	TOTAL
1	11' Aluminum Dump Body w/Snow Equipment	\$ -	\$ 75,570.00
	* SEE ATTACHED SPECIFICATIONS *		
	CO STARS 25-044 CONTRACT		

Quote Accepted By _____	Unit \$ 75,570.00
Title: _____	
Date : _____	
	TOTAL \$ 75,570.00

Salesman: Perry Ohm
Title: Territory Manager
 412-721-6990

Office Use Only

SALES FOR OVER 50 YEARS

Quote prices applicable 60 days from date of Quote