

CITY OF JOHNSTOWN, CAMBRIA COUNTY, PENNSYLVANIA

RESOLUTION NO. 10571

A RESOLUTION OF THE CITY COUNCIL OF THE CITY OF JOHNSTOWN, CAMBRIA COUNTY, PENNSYLVANIA AUTHORIZING THE CITY MANAGER TO SIGN ALL DOCUMENTS NECESSARY TO LEASE TO OWN A 2024 10-TON FREIGHTLINER 114SD PLUS TRUCK CHASIS FROM BERMAN TRUCK GROUP AND A 10' 6" ALUMINUM DUMP BED WITH SNOW EQUIPMENT FROM A & H EQUIPMENT

WHEREAS, the City of Johnstown Public Works Department would like to lease a 2024 10-ton Freightliner 114SD Plus truck chassis from Berman Truck Group and a 10' 6" Aluminum Dump body with Snow Equipment from A & H Equipment; and

WHEREAS, the lease of the truck chassis and dump body will be made from First Capital Equipment Leasing Corp. for (7) seven year paid quarterly; and

WHEREAS, during a search for a 2024 10-ton Freightliner 114SD plus truck chassis and Aluminum Dump Body Berman Truck Group and A & H Equipment offered the lowest COSTAR quote for a 2024 10-ton truck at \$128,355.00 and the Aluminum Dump Body with Snow Equipment \$75,570.00 for a total quote of \$203,925.00 leased for (7) seven years paid quarterly whereas the account to be charged is 18.434.74.072.00 in the capital fund.

NOW, THEREFORE, BE IT RESOLVED, the City Council of the City of Johnstown, hereby authorizes the City Manager and/or his designee to sign all documents and take all actions necessary to lease to own from First Capital Equipment Leasing Corp. the 2024 10-ton Freightliner 114SD Plus chassis from Berman Truck Group and 10' 6" Aluminum Dump Body with Snow Equipment from A & H Equipment.

ADOPTED: June 14, 2023

By the following vote:

Yeas: Mrs. Mock, Ms. Huchel, Mayor Janakovic, Rev. King, Mr. Britt, Mr. Arnone, Mr. Capriotti

Nays:

Absent:



Frank Janakovic, Mayor
Michael Capriotti, Deputy Mayor

ATTEST:

I do hereby certify that the foregoing is a true and correct copy of Resolution No. **10571** as the same adopted by the City Council of the City of Johnstown, Pennsylvania.



Ethan Imhoff, City Manager

Prepared for:
JARED CAMPAGNE
JOHNSTOWN CITY OF
419 6th AVENUE
JOHNSTOWN, PA 15901
Phone: 814-533-2089



Prepared by:
Tim Magrini
BERMAN TRUCK GROUP
1844 RICH HIGHWAY
DU BOIS, PA 15801
Phone:

A proposal for
JOHNSTOWN CITY OF

Prepared by
BERMAN TRUCK GROUP
Tim Magrini

May 23, 2023

Freightliner 114SD Plus

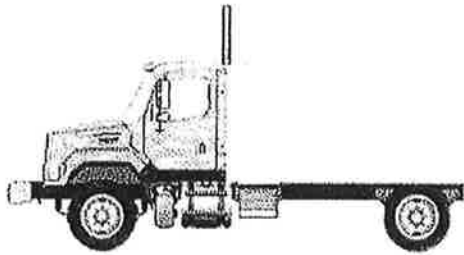

Components shown may not reflect all spec'd options and are not to scale

Application Version 11.8.006
Data Version PRL-27D.043
CITY OF JOHNSTOWN 114SD SBA

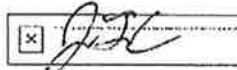

Tender #
05/23/2023 10:04 AM
Page 1 of 21

Prepared for:
 JARED CAMPAGNE
 JOHNSTOWN CITY OF
 419 6th AVENUE
 JOHNSTOWN, PA 15901
 Phone: 814-533-2089



Prepared by:
 Tim Magrini
 BERMAN TRUCK GROUP
 1844 RICH HIGHWAY
 DU BOIS, PA 15801
 Phone:

Q U O T A T I O N

114SD PLUS CONVENTIONAL CHASSIS

SET BACK AXLE - TRUCK CUM X12 430V HP @ 1900 RPM, 1550 LB-FT @ 1000 RPM, 2000 GOV RPM, VOC ALLISON 4500 RDS AUTOMATIC TRANSMISSION WITH PTO PROVISION RS-23-160 23,000# R-SERIES SINGLE REAR AXLE 23,000# FLAT LEAF SPRING REAR SUSPENSION WITH HELPER AND RADIUS ROD DETROIT DA-F-14.7-3 14,700# FF1 71.5 KPI/3.74 DROP SINGLE FRONT AXLE	14,600# TAPERLEAF FRONT SUSPENSION 114 INCH BBC FLAT ROOF ALUMINUM CONVENTIONAL CAB 3925MM (155 INCH) WHEELBASE 11/32X3-1/2X10-15/16 INCH STEEL FRAME (8.73MMX277.8MM/0.344X10.94 INCH) 120KSI 1825MM (72 INCH) REAR FRAME OVERHANG 1/4 INCH (6.35MM) C-CHANNEL INNER FRAME REINFORCEMENT
---	--

		PER UNIT		TOTAL
VEHICLE PRICE	TOTAL # OF UNITS (1)	\$	129,863	\$ 129,863
EXTENDED WARRANTY		\$	3,038	\$ 3,038
DEALER INSTALLED OPTIONS		\$	0	\$ 0
CUSTOMER PRICE BEFORE TAX		\$	132,901	\$ 132,901
TAXES AND FEES				
TAXES AND FEES		\$	0	\$ 0
OTHER CHARGES		\$	6	\$ 6
TRADE-IN				
TRADE-IN ALLOWANCE		\$	(4,552)	\$ (4,552)
BALANCE DUE	(LOCAL CURRENCY)	\$	128,355.00	\$ 128,355.00

COMMENTS:

Projected delivery on ___/___/___ provided the order is received before ___/___/___.

APPROVAL:

Please indicate your acceptance of this quotation by signing below:

Customer:  Date: 5/24/2023



Financing that works for you.

See your local dealer for a competitive quote from Daimler Truck Financial, or contact us at Information@dtfoffers.com.

Daimler Truck Financial offers a variety of finance, lease and insurance solutions to fit your business needs. For more information about our products and services, visit our website at www.daimler-truckfinancial.com.



Prepared for:
 JARED CAMPAGNE
 JOHNSTOWN CITY OF
 419 6th AVENUE
 JOHNSTOWN, PA 15901
 Phone: 814-533-2089



Prepared by:
 Tim Magrini
 BERMAN TRUCK GROUP
 1844 RICH HIGHWAY
 DU BOIS, PA 15801
 Phone:

DIMENSIONS

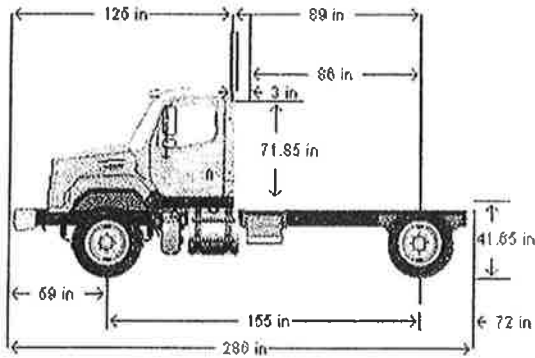

VEHICLE SPECIFICATIONS SUMMARY - DIMENSIONS

Model.....	114SD
Wheelbase (545).....	3925MM (155 INCH) WHEELBASE
Rear Frame Overhang (552).....	1825MM (72 INCH) REAR FRAME OVERHANG
Fifth Wheel (578).....	NO FIFTH WHEEL
Mounting Location (577).....	NO FIFTH WHEEL LOCATION
Maximum Forward Position (in).....	0
Maximum Rearward Position (in).....	0
Amount of Slide Travel (in).....	0
Slide Increment (in).....	0
Desired Slide Position (in).....	0.0
Cab Size (829).....	114 INCH BBC FLAT ROOF ALUMINUM CONVENTIONAL CAB
Sleeper (682).....	NO SLEEPER BOX/SLEEPER CAB
Exhaust System (016).....	RH OUTBOARD UNDER STEP MOUNTED HORIZONTAL AFTERTREATMENT SYSTEM ASSEMBLY WITH RH B-PILLAR MOUNTED VERTICAL TAILPIPE

TABLE SUMMARY - DIMENSIONS





PITTSBURGH - 620 W Beaver Street, Zelienople, PA 16063 412-257-1160

HARRISBURG - 1405 B Hagy Way, Harrisburg, PA 17110 717-724-0310

SOMERSET - 241 E Garret Street, Somerset, Pa 15501 814-444-6403

800-753-7566 Fax PGH 412-257-4471 Fax HAR - 717-724-0309

Customer City of Johnstown
 Name Jared Campagna
 Address 419 Sixth Street
 City Johnstown State PA ZIP 15901
 Phone _____

Misc _____ **QUOTE**
 Date 5/17/2023
 Quote No. 02152023AL
 Rep PMO

Qty	Description	Unit Price	TOTAL
1	10'6" Aluminum Dump Body w/Snow Equipment * SEE ATTACHED SPECIFICATIONS * CO STARS 25-044 CONTRACT	\$ -	\$ 75,570.00

Quote Accepted By [Signature]
 Title: Public Works Director
 Date: 5-24-2023

Unit	\$ 75,570.00
TOTAL	\$ 75,570.00

Salesman: Perry Ohm
 Title: Territory Manager
412-721-6990

Office Use Only

SALES FOR OVER 50 YEARS

Quote prices applicable 60 days from date of Quote